

L Series Lead Free Reflow Oven



Introduction:

L series lead-free reflow oven I.C.T's mature product after years of market testing. L Series Reflow oven has maintained a larger share of the market for many years. Its unparalleled heating performance and temperature control system meets the requirements of various welding processes. It is I.C.T's crystallization of years technical research and development. L Series Lead-free reflow is high-end reflow products committed to keeping up with market demand to enhance customers competitiveness. Its new design concept fully meets the needs of increasingly diverse processes. And considering the future direction of the industry, entirely suitable for communications, automotive electronics, home appliances, computers and other consumer electronic products.

Features:

1. Control System: PC+Siemens PLC control system, accurate temperature control and more stable, ensures temperature stability rate to be more than 99.99%.
2. Hot air system: first-class heating module, the best temperature zone interval design makes optimum temperature uniformity and repeat. The effective utilization and thermal compensation efficiency, it needs less than 20 minutes from temperature control accuracy $\pm 1^{\circ}\text{C}$ ambient temperature to a temperature stabilization.
3. Monitoring Software: Windows interface, traditional and simplified Chinese and English online free switch, and operator password management, easy to operate. Operation records, temperature curve measurement and analysis functions, virtual simulation, fault self-diagnosis, process monitoring, automatic generate and save process control documents, substrate transport dynamic display.
4. Cooling System: new cooling zone, quick and easy adjustment, easily reach the cooling requirements of different slopes.
5. Temperature protection: I.C.T using third-party over-temperature protection, multiple layers protection to ensure safe operation.
6. Products comply with CE, CCC, UL , other standards and specifications.
7. User-friendly design: fault detection (such as heaters abnormal alarm, etc.), regular maintenance reminders, the economy functions and tool-free maintenance, reducing equipment failure rates.
8. Heating module: transverse reflow design makes temperature from each zone is not influenced by neighbour to ensure accurate temperature curve, while ensuring a high production capacity and heat exchange capacity to achieve high adaptability (to meet the soldering of automotive, communications, electronics, computers and mobile phones consumer electronics.)
9. Hot air motor with independently inverter controlled, set operating frequencies depending on different technology to meet a variety of lead-free processes.
10. Machine using zero gas source design, furnace cover with motor lifting, safety rod support, providing significant security.
11. Main parts: imported main parts ensure equipment runs smoothly and lower the maintenance cost.
12. Customers can choose optional flux processing system according to their own production features to ensure furnace chamber clean.
13. Closed-loop transmission speed control systems, transportation accuracy $\pm 2\text{mm}/\text{min}$, ensuring more stable transmission speed.
14. Central support, dual transmission, external water cooling system is optional.

TOP Advantage:

1. Simple: Combined with advanced international concepts, based on the Oriental-designed operating system, easy to understand, easy to learn, easy to maintain.
2. Expertise: Learn imported reflow oven's advanced design concepts, and the machine core components are using imported top brands.
3. Hedging: Import hardware configuration, low failure rate in production, more than a decade service life.

- 4. Safety: Based on the general rules of international design, close to imported reflow rating, the highest security level.
- 5. Stable: Mature software, hardware and top production processes ensures stability of each equipment.

Pictures:

1. Transportation system and rectifying plate structure

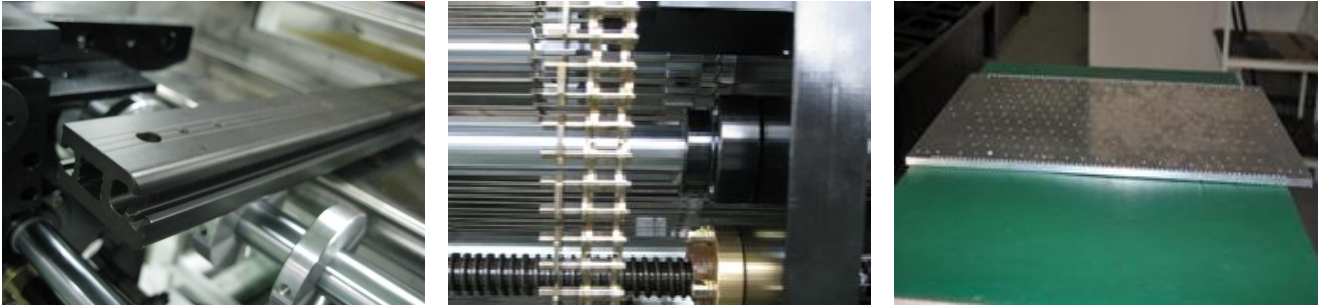

2. Chamber and high temperature structure parts

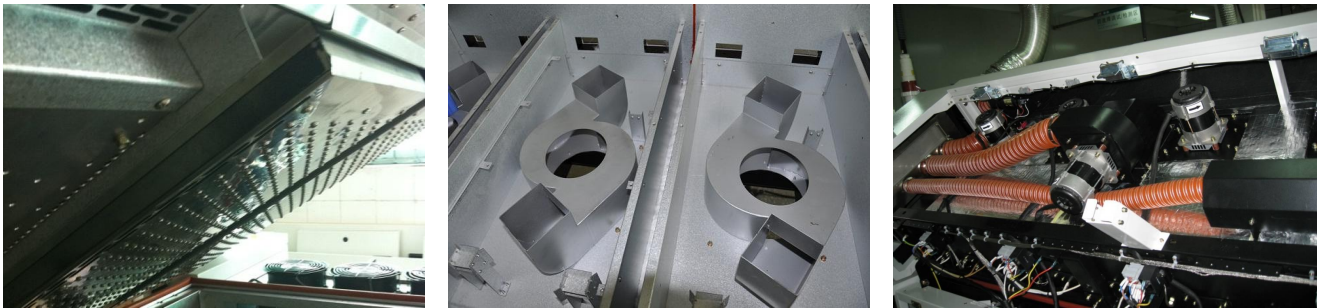

Specification:

S - Standard, O - Option, M - Manual, A - Auto, N/A - Not Available					
Specifications	L8	L10	Specifications	L8	L10
Dimension (mm)	5000*1250*1460	5800*1250*1460	Ups	S	
Standard Color	Computer Grey		Conveyor Direction	L→R (Option: R→L)	
Weight	Approx.1600KG	Approx.1800KG	Computer	Lenovo	
Number of Heating Zones	Up8/Bottom8	Up10/Bottom10	Max.Width of PCB	400mm	
Length of Heating Zones	3121mm	3891mm	Temperature Deviation	±1.0°C	
Rail Width Adjustment	M (Option: A)		Length of Cooling Zones	600mm	
Exhaust Volume	10M ³ /min*2 Exhausts		Center Support	O	
Control System	PLC+Computer		Temperature Control Precision	±1.0°C	
Temperature Control Method	PID+SSR		Max. Temp. Gap Between Preheat Zones	40°C	
Transmission Agent	Chain+Mesh		Temperature Alarm	S	
Electric Supply Required	3phase, 380V 50/60Hz		Siemens PLC	S	
Power For Warm Up	55KW	64KW	Lubrication Auto-Afflux	S	

Power Consumption	8KW	12KW	On Line Editing	S
Warming Time	Approx.25 minute		Temp. Thermocouple Slot	S
Temp. Setting Range	Room Temp.-- 300℃		Rail Number	1 Lane
Conveyor Height	900±20mm		Components Clearance	Top/Bottom is 25mm
Conveyor Speed Range	300~2000mm/min		Number of Cooling Zones	2
Fixed Rail Side	Front Fixed (Option: Rear Fixed)		Process Data & Status Storage	S
Cooling Method	Forced-Air Motor and fan (Standard)		Max. Temp. Gap Between Pre & Refl Zone	50℃

Configuration:

Item	Name	Brand	Note	Item	Name	Brand	Note
1	Computer	Lenovo	China	11	Binding post	Phoenix	USA
2	Display	Lenovo	China	12	Light button	Schneider	France
3	PLC	Siemens	Germany	13	Buzzer	Koino	Korea
4	Solid relay	Carlogavazzi	Switzerland	14	Frequency converter	Delta	Taiwan
5	Relay base	Carlogavazzi	Switzerland	15	Solid replay	Schneider/	France
6	Contactoer	Schneider	France	16	Fuse	DELIXI	China
7	Wire	Jin Longyu	China	17	Button	Schneider	France
8	Air switch	DELIXI	China	18	Emergency Button	Schneider	France
9	Power Supply	MW	Taiwan	19	UPS	STK	USA
10	Switch for light	Yamatake	Japan	20	T-color light	Dahong	China

Item	Name	Brand	Note	Item	Name	Brand	Note
1	Transmission motor	Panasonic	Japan	10	High Temp. Wire	Hotset	Germany
2	High Temp. Motor	Sanyue	Taiwan	11	Cooling motor	Sanyue	Taiwan
3	Heating wire	Hotset	Germany	12	Cooling fan	Sanyue	Taiwan
4	High temperature fan	Sanyue	Taiwan	13	Fan	Jianzhun	Taiwan
5	Guide rail	I.C.T	China	14	Mesh	TSUBAKI	Japan
6	Chain	KMC	Taiwan	15	High temp. adhesive tape	Xinyue	Japan
7	Chain shackle	KMC	Taiwan	16	Gear box	Panasonic	Japan
8	Heat cotton	RockWool	Germany	17	Rotary drum	TSUBAKI	Japan
9	Magnetic valve	AIRTAC	Taiwan	18	Oil cup	Xinrong	China

Standard Accessories:

No.	Item	Quantity
1	Computer	1 set
2	Operation Software	1 set
3	Heating	1 pcs
4	Fuse	1 pcs

5	Relay	2 pcs
6	Solid State Relay	1 pcs
7	K-type Test Line	1 pcs
8	Manual	1 book
9	Tool Case	1 set

* I.C.T keeps working on quality and performance, specifications and appearance may be updated without particular notice.

Dimension:

L8

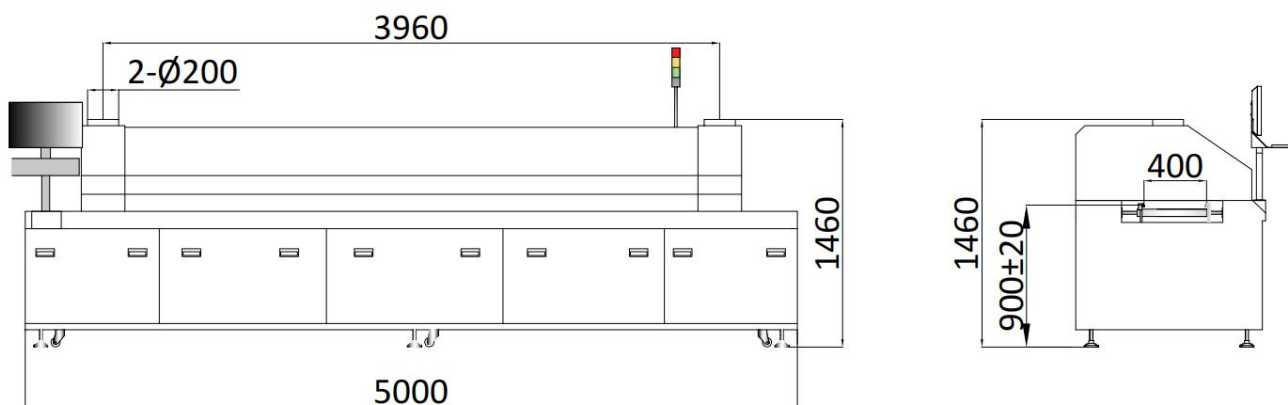

L10

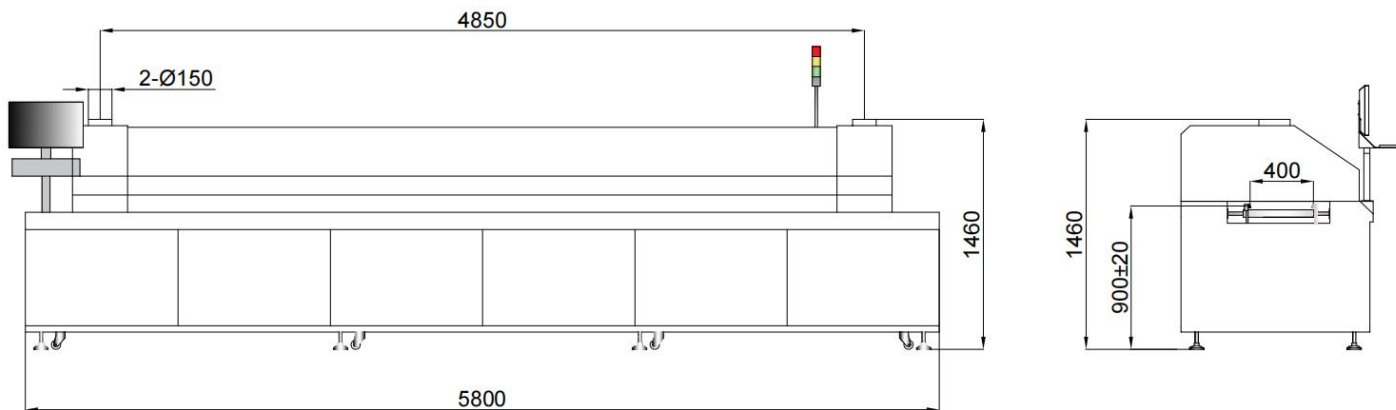

YouTube Video Link: <https://youtu.be/PrwsgQfzx4>

Thanks for choosing I.C.T.
I.C.T looks forward to win-win cooperation.
Thank you.